

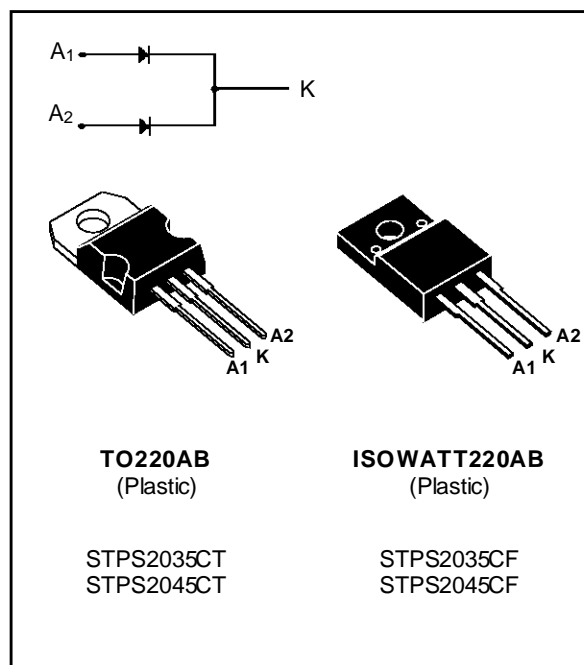
## POWER SCHOTTKY RECTIFIER

- VERY SMALL CONDUCTION LOSSES
- NEGLIGIBLE SWITCHING LOSSES
- EXTREMELY FAST SWITCHING
- LOW FORWARD VOLTAGE DROP
- HIGH AVALANCHE CAPABILITY
- LOW THERMAL RESISTANCE
- INSULATED PACKAGE :  
Insulating voltage = 2000V DC  
Capacitance = 12pF

### DESCRIPTION

Dual center tap schottky rectifier suited for switch-mode power supply and high frequency DC to DC converters.

Packaged in TO220AB and ISOWATT220AB, this device is intended for use in low voltage, high frequency inverters, free wheeling and polarity protection applications.



### ABSOLUTE RATINGS (limiting values)

Symbol	Parameter		Value	Unit	
$I_{F(RMS)}$	RMS Forward Current		Per diode 30	A	
$I_{F(AV)}$	Average Forward Current $\delta = 0.5$	TO220AB	$T_c = 135^\circ\text{C}$ Per diode	10	A
		ISOWATT220AB	$T_c = 120^\circ\text{C}$ Per device	20	
$I_{FSM}$	Surge Non Repetitive Forward Current		$T_p = 10 \text{ ms}$ Sinusoidal Per diode	180	A
$I_{RRM}$	Peak Repetitive Reverse Current		$T_p = 2 \mu\text{s}$ $F = 1\text{KHz}$ Per diode	1	A
$T_{stg}$ $T_j$	Storage and Junction Temperature Range		- 65 to + 150 - 65 to + 150	$^\circ\text{C}$	
dV/dt	Critical Rate of Rise of Reverse Voltage		1000	V/ $\mu\text{s}$	

Symbol	Parameter	STPS		Unit
		2035CT 2035CF	2045CT 2045CF	
$V_{RRM}$	Repetitive Peak Reverse Voltage	35	45	V

# STPS2035CT/CF / STPS2045CT/CF

## THERMAL RESISTANCE

Symbol	Parameter		Value	Unit	
R <sub>TH(j-c)</sub>	Junction-case	TO220AB	Per diode total	2.2 1.3	°C/W
		ISOWATT220AB	Per diode total	4.5 3.5	
R <sub>TH(c)</sub>	Coupling	TO220AB		0.3	°C/W
		ISOWATT220AB		2.5	

When the diodes 1 and 2 are used simultaneously :  
 $\Delta T_{J(\text{diode } 1)} = P(\text{diode } 1) \times R_{TH(\text{Per diode})} + P(\text{diode } 2) \times R_{TH(c)}$

## ELECTRICAL CHARACTERISTICS

### STATIC CHARACTERISTICS PER DIODE

Symbol	Tests Conditions		Min.	Typ.	Max.	Unit
I <sub>R</sub> *	T <sub>j</sub> = 25°C	V <sub>R</sub> = V <sub>RRM</sub>			100	μA
	T <sub>j</sub> = 125°C				15	mA
V <sub>F</sub> **	T <sub>j</sub> = 125°C	I <sub>F</sub> = 20 A			0.72	V
	T <sub>j</sub> = 125°C	I <sub>F</sub> = 10 A			0.57	
	T <sub>j</sub> = 25°C	I <sub>F</sub> = 20 A			0.84	

Pulse test : \* t<sub>p</sub> = 5 ms, duty cycle < 2 %  
 \*\* t<sub>p</sub> = 380 μs, duty cycle < 2%

To evaluate the conduction losses use the following equation :  
 $P = 0.42 \times I_{F(AV)} + 0.015 I_{F(RMS)}^2$

Fig. 1 : Average forward power dissipation versus average forward current. (Per diode)

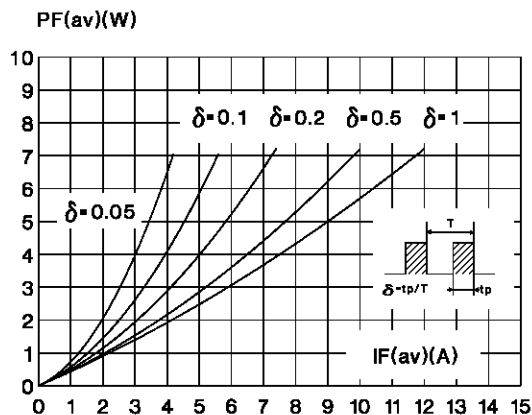


Fig. 2 : Average current versus ambient temperature. (duty cycle : 0.5) (Per diode) (TO220AB)

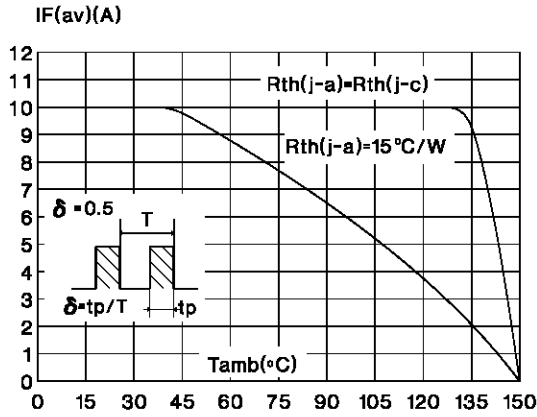


Fig. 3 : Average current versus ambient temperature. (duty cycle : 0.5) (Per diode) (ISOWATT220AB)

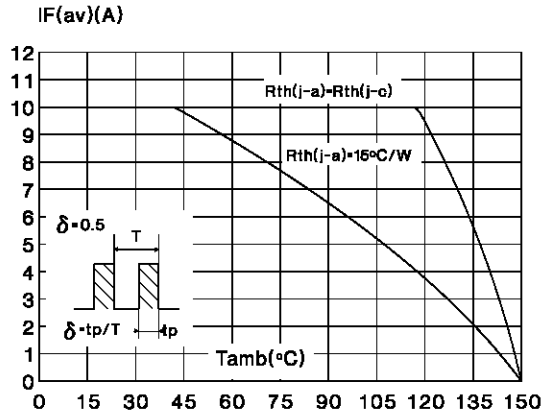


Fig. 4 : Non repetitive surge peak forward current versus overload duration. (Maximum values) (Per diode) (TO220AB)

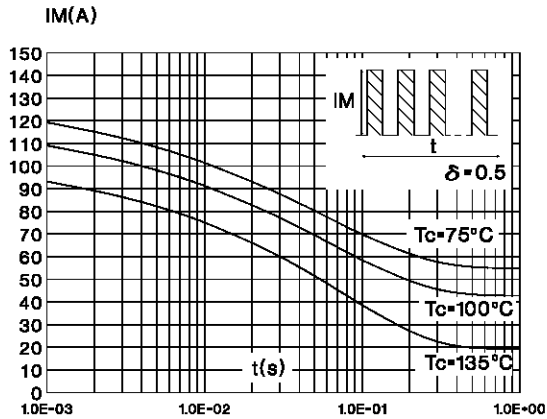


Fig. 5 : Non repetitive surge peak forward current versus overload duration. (Maximum values) (Per diode) (ISOWATT220AB)

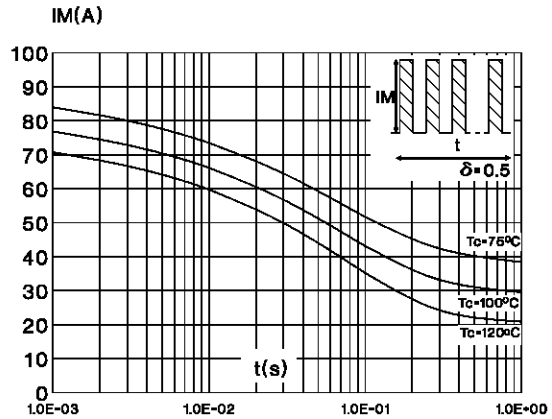


Fig. 6 : Relative variation of thermal transient impedance junction to case versus pulse duration. (TO220AB)

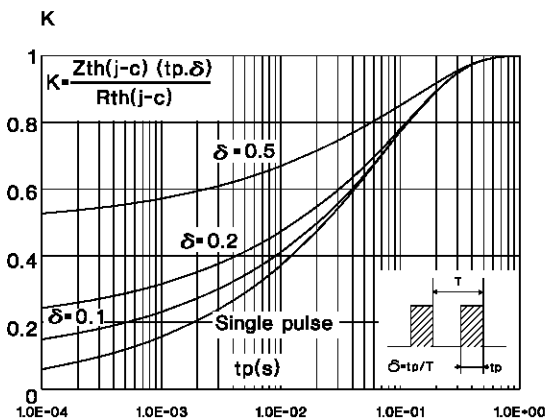
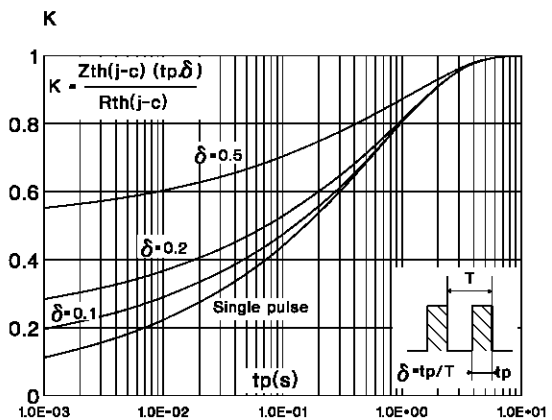
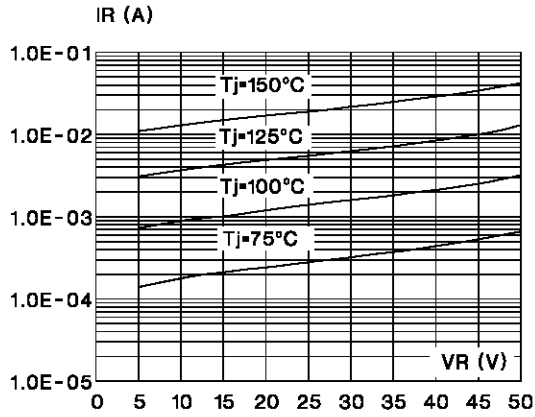


Fig. 7 : Relative variation of thermal transient impedance junction to case versus pulse duration. (ISOWATT220AB)

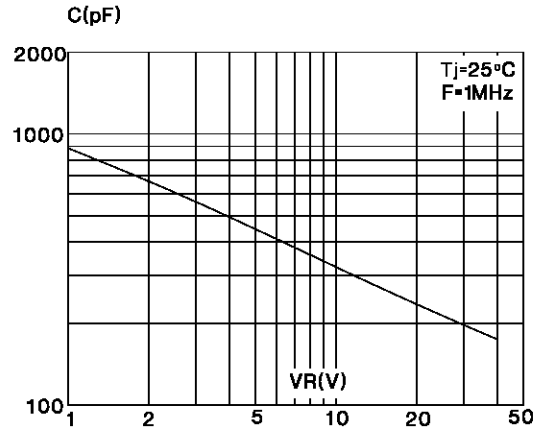


# STPS2035CT/CF / STPS2045CT/CF

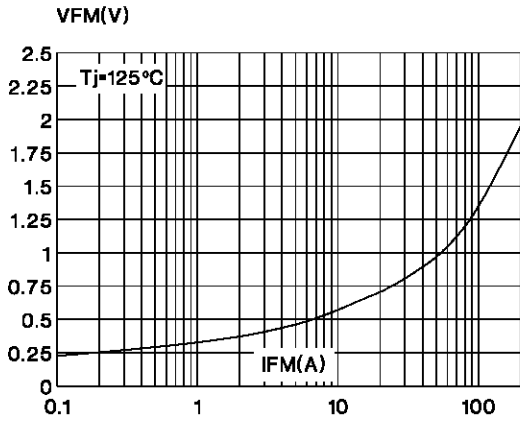
**Fig. 8** : Reverse leakage current versus reverse voltage applied. (Typical values) (Per diode)



**Fig. 9** : Junction capacitance versus reverse voltage applied. (Typical values) (Per diode)

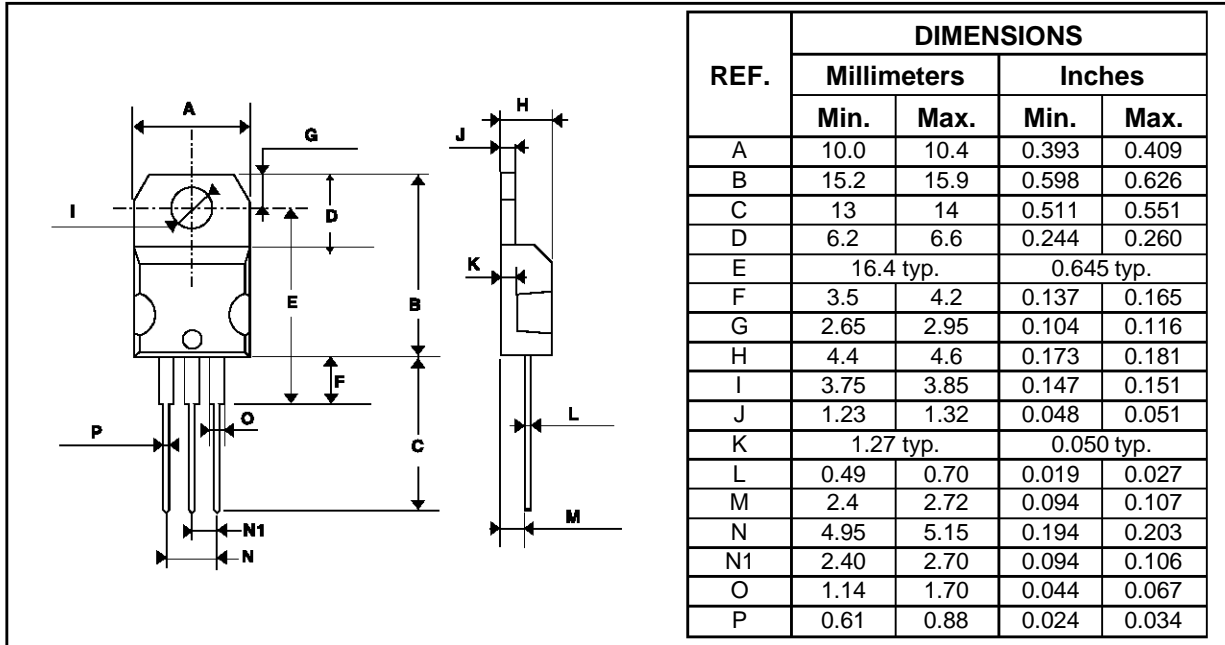


**Fig. 10** : Forward voltage drop versus forward current. (Maximum values) (Per diode)



**PACKAGE MECHANICAL DATA**

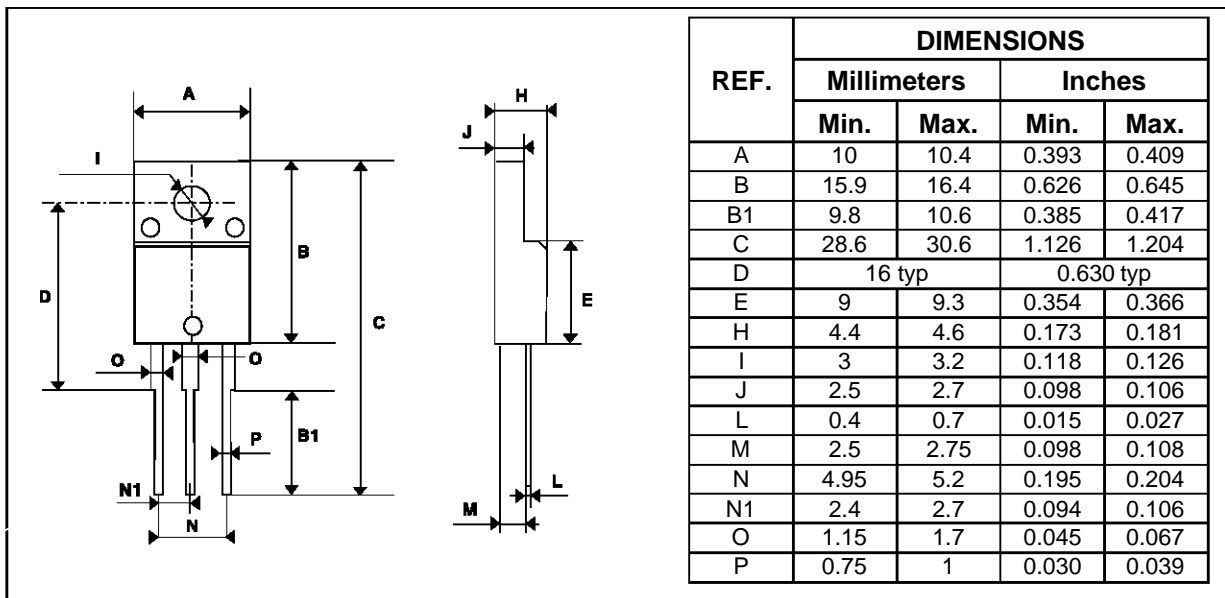
TO220AB (JEDEC outline)



Cooling method : C  
 Marking : Type number  
 Weight : 2 g  
 Recommended torque value : 0.55m.N  
 Maximum torque value : 0.7m.N

**PACKAGE MECHANICAL DATA**

ISOWATT220AB (JEDEC outline)



Cooling method : C  
 Marking : Type number  
 Weight : 2.1 g  
 Recommended torque value : 0.55m.N  
 Maximum torque value : 0.70m.N  
 Electrical isolation : 2000V DC  
 Capacitance : 12pF

Information furnished is believed to be accurate and reliable. However, SGS-THOMSON Microelectronics assumes no responsibility for the consequences of use of such information nor for any infringement of patents or other rights of third parties which may result from its use. No license is granted by implication or otherwise under any patent or patent rights of SGS-THOMSON Microelectronics. Specifications mentioned in this publication are subject to change without notice. This publication supersedes and replaces all information previously supplied. SGS-THOMSON Microelectronics products are not authorized for use as critical components in life support devices or systems without express written approval of SGS-THOMSON Microelectronics.

© 1994 SGS-THOMSON Microelectronics - All Rights Reserved

TURBOSWITCH, TRANSIL, TRISIL, SNUBBERLESS are Trademarks of SGS-THOMSON Microelectronics.

SGS-THOMSON Microelectronics GROUP OF COMPANIES

Australia - Brazil - France - Germany - Hong Kong - Italy - Japan - Korea - Malaysia - Malta - Morocco - The Netherlands -  
Singapore - Spain - Sweden - Switzerland - Taiwan - Thailand - United Kingdom - U.S.A